

INSTALLATION INSTRUCTIONS

**FORTIS FRONT BUMPER
2017 FORD SUPER DUTY F250-350**

STEELCRAFT

**FORTIS FRONT BUMPER
2017 FORD SUPER DUTY F250-350**

PARTS LIST:

1	Fortis Front Bumper	18	12mm Lock Washers
1	Driver/left Side Mounting Bracket	18	12mm Hex Nuts
1	Passenger/right Side Mounting Bracket	4	8mm x 25mm Hex Bolts
2	Plastic Plugs for license plate	2	8mm x 16mm Hex Bolts
1	Driver/left Side LED Light "L" Bracket	10	8mm x 24mm x 2mm Flat Washers
1	Passenger/right Side LED Light "L" Bracket	6	8mm Lock Washers
1	Adaptive Cruise Control, ACC, Bracket	4	8mm Hex Nuts
1	ACC Plastic Cover	3	6mm x 25mm Button Head Bolts
2	10mm Rubber Plugs	3	6mm x 18mm x 1.6mm Flat Washers
4	12mm x 90mm x 20mm Bolt Plates	3	6mm Lock Washers
4	12mm Plastic Retainers	3	6mm Hex Nuts
14	12-1.75mm x 50mm Hex Bolts	1	Allen Wrench
32	12mm x 32mm x 3mm Flat Washers		

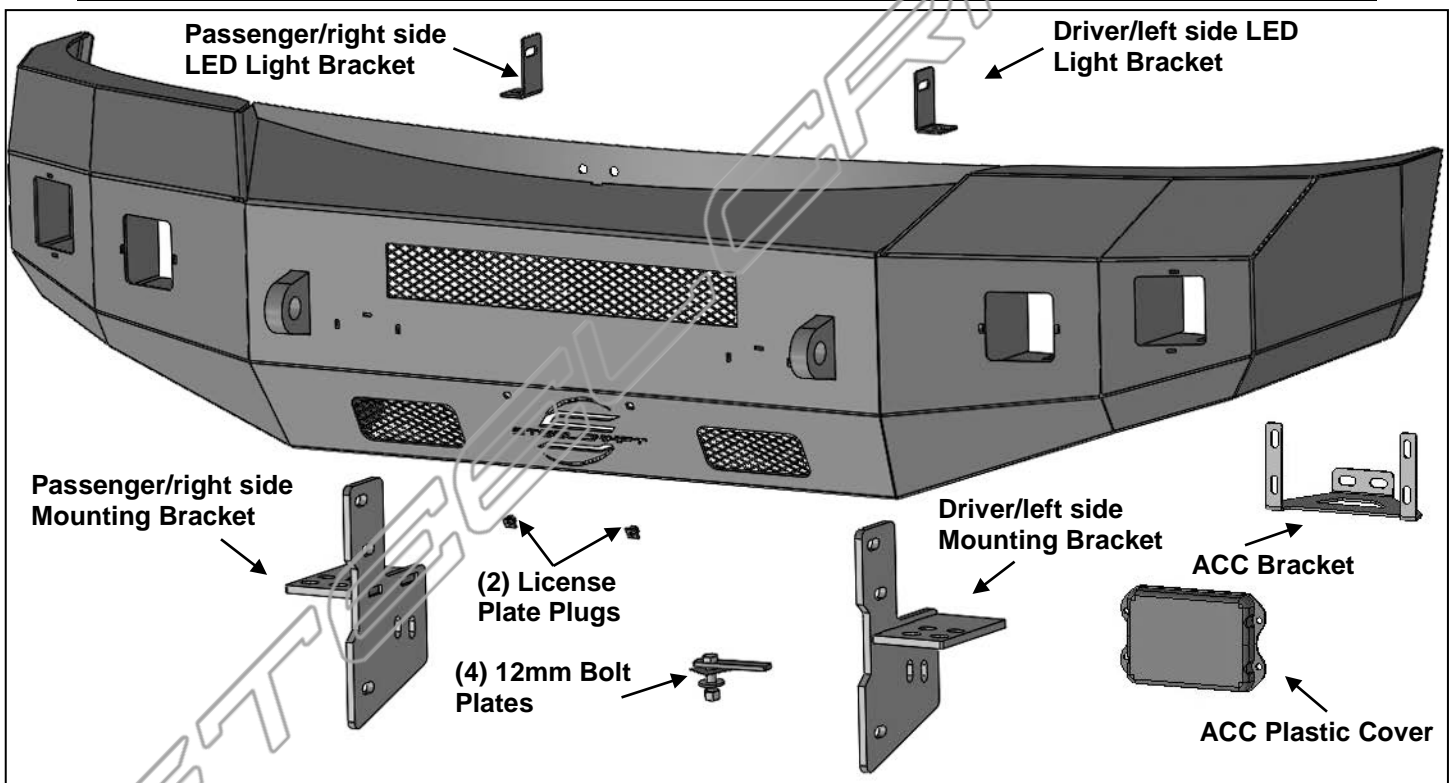

PROCEDURE:

REMOVE CONTENTS FROM BOX. VERIFY ALL PARTS ARE PRESENT. READ INSTRUCTIONS CAREFULLY BEFORE STARTING INSTALLATION. BUMPER IS HEAVY, ASSISTANCE IS HIGHLY RECOMMENDED TO AVOID POSSIBLE INJURY OR DAMAGE TO THE VEHICLE.

1. Remove the license plate and bracket. On models with factory fog lights, unplug wiring harness, **(Figure 1)**. Unplug and remove the adaptive cruise control, if equipped.
2. Remove the outer bumper supports attaching the outer ends of the bumper to the sides of the frame, **(Figure 2)**. Remove the plastic covers from the tow hooks to uncover the bumper bolts, **(Figure 3)**.
3. Place blocks or jack stands under the front bumper to support it during mounting bolt removal. Once the bumper has been safely supported, remove the (8) factory bumper bolts, **(Figure 4)**.

WARNING! Assistance is required to hold the bumper in place during bolt removal to prevent the bumper from falling. Carefully slide the bumper off over the tow hooks.

**FORTIS FRONT BUMPER
2017 FORD SUPER DUTY F250-350**

4. Remove the passenger/right side tow hook from the end of the frame, **(Figure 5)**. Next, remove the (4) factory hex nuts, lower frame extension and double bolt plates from the end of the frame, **(Figures 1 & 5)**. Repeat this Step to remove the driver/left side tow hook and lower frame extension.
5. Locate the passenger/right side frame mounting location, **(Figure 6)**. Insert (2) 12mm Bolt Plates in through the frame channel and out the (2) inner holes of the frame, **(Figures 6 & 7)**. Use the (2) 12mm Plastic Retainers to secure the Bolt Plates tight against the frame. Select the Passenger/right side Mounting Bracket, **(Figure 7)**. Attach the Bracket to the Bolt Plates using (2) 12mm Flat Washers, (2) 12mm Lock Washers and (2) 12mm Hex Nuts, **(Figure 7)**. Do not tighten hardware at this time.
6. Use the included (4) 12mm Hex Bolts, (8) 12mm Flat Washers, (4) 12mm Lock Washers and (4) 12mm Hex Nuts to attach the Bracket to the top of the frame, **(Figure 8)**. Do not tighten hardware.
7. Repeat **Steps 5 & 6** for Driver/left side Bracket installation.
8. **Optional Center LED light installation** (sold separately).
 - a. Select the L/R "L" Brackets. **NOTE:** "L" Brackets are offset for universal fitment for most LED bar style lights. Attach the LED light assembly to the "L" Brackets with the included (2) 8mm x 16mm Hex Bolts, (2) 8mm Lock Washers and (2) 8mm Flat Washers, **(Figure 9)**. Do not fully tighten hardware at this time. **NOTE:** "L" Brackets may require modification for hardware larger than 8mm or use brackets supplied with light if possible.
 - b. Attach the light and brackets to the top of the (2) tabs on the back of the Bumper with the included 8mm x 25mm Hex Bolts, (4) 8mm Flat Washers, (2) 8mm Lock Washers and (2) 8mm Hex Nuts, **(Figure 9)**. Adjust light position and tighten hardware.
 - c. Follow light manufacturer's instructions to wire the light to the vehicle's electrical system once Bumper has been fully installed.
9. Determine if vehicle is equipped with adaptive cruise control. **Vehicles without ACC**, skip to **Step 10**.
 - a. Select the ACC Plastic Cover and the ACC Support Bracket, **(Figure 10)**. Insert (3) 6mm x 25mm Button Head Bolts through the (3) holes on the Plastic Cover, the Bracket and out through the adaptive cruise control. Secure with (3) 6mm Flat Washers, (3) 6mm Lock Washers and (3) 6mm Hex Nuts, **(Figure 10)**. **NOTE:** To prevent the Plastic Cover from tearing, do not over tighten Bolts.
 - b. On some Bumpers, drilling may be required on front trim of Bumper. Select the ACC Bracket. Align the Bracket up against the center of the front trim on the Bumper, **(Figure 11)**. Mark through the center of the slots on the Bracket and onto the Bumper trim. Use a 5/16" drill bit to drill out (2) holes through the Bumper front trim. **NOTE:** Do not drill through the edges of the Bumper trim.
 - c. Attach the ACC assembly to the front of the bumper using (2) 8mm x 25mm Hex Bolts, (4) 8mm Flat Washers, (2) 8mm Lock Washers and (2) 8mm Hex Nuts, **(Figure 11)**.
 - d. Tighten all ACC hardware and continue to **Step 10**.
10. **LED light installation at ends of bumper** (sold separately).
 - a. Insert light into opening and up to mounting slots.
 - b. Follow light manufacturer's instructions to attach each light to slot in the top of the light opening. On two light systems, attach flood light to outer slot and spot light to inner slot.
 - c. Repeat the above steps for driver side light installation.
 - d. Follow light manufacturer's instructions to properly wire the light to the vehicle electrical system.
11. With assistance, carefully position the Bumper Assembly up to the inside of the Mounting Brackets. Temporarily support the weight of the Bumper. **WARNING:** To avoid possible injury or damage to the vehicle, do not proceed until the bumper is fully and safely supported. Models with LED light, check for clearance before fully installing Bumper assembly.
12. Attach the Bumper to the inside of the Mounting Brackets with the included (6) 12mm Hex Bolts, (12) 12mm Flat Washers, (6) 12mm Lock Washers and (6) 12mm Hex Nuts, **(Figure 12)**. Do not tighten.
13. Insert (2) Plastic Plugs into the square holes in the front of the Bumper. Reuse the factory screws to attach the license plate to the plastic plugs, **(Figure 13)**.
14. Level and adjust the bumper and fully tighten all hardware.
15. Do periodic inspections to the installation to make sure that all hardware is secure and tight.

To protect your investment, wax this product after installing. Regular waxing is recommended to add a protective layer over the finish. Do not use any type of polish or wax that may contain abrasives that could damage the finish. Mild soap may be used to clean the Front Bumper assembly.

**FORTIS FRONT BUMPER
2017 FORD SUPER DUTY F250-350**

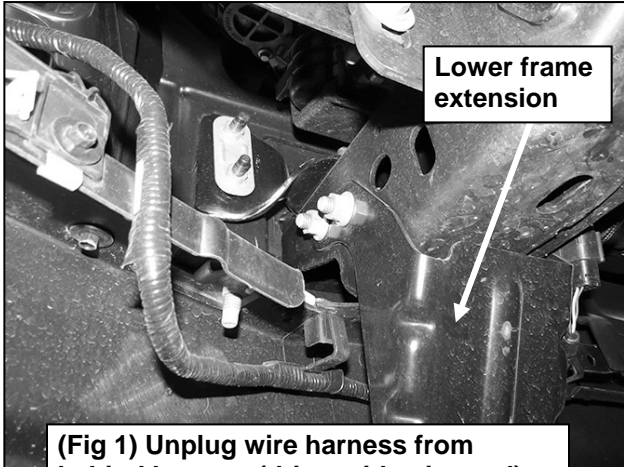

(Fig 1) Unplug wire harness from behind bumper (driver side pictured)

WARNING! Do not crawl under bumper unless the bumper is properly supported on blocks or stands or the bumper may fall.

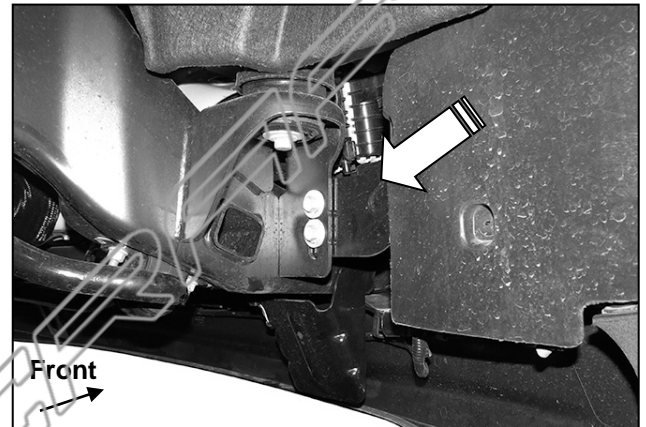

(Fig 2) Remove outer bumper support brackets between frame and bumper (arrow)

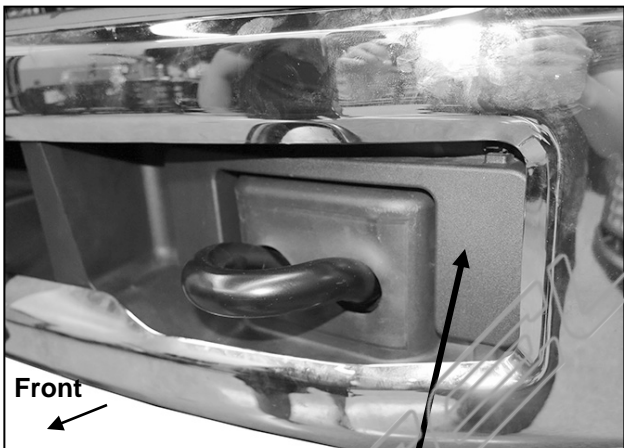

(Fig 3) Remove plastic cover around tow hook



(Fig 4) Remove bumper bolts (driver side pictured)

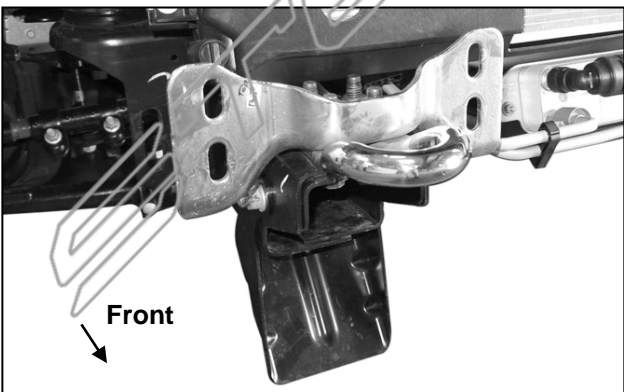

(Fig 5) Remove tow hook assembly and lower frame extension

WARNING! Do not remove bumper bolts unless the bumper is properly supported on blocks or stands or the bumper may fall.

**FORTIS FRONT BUMPER
2017 FORD SUPERDUTY F250-350**

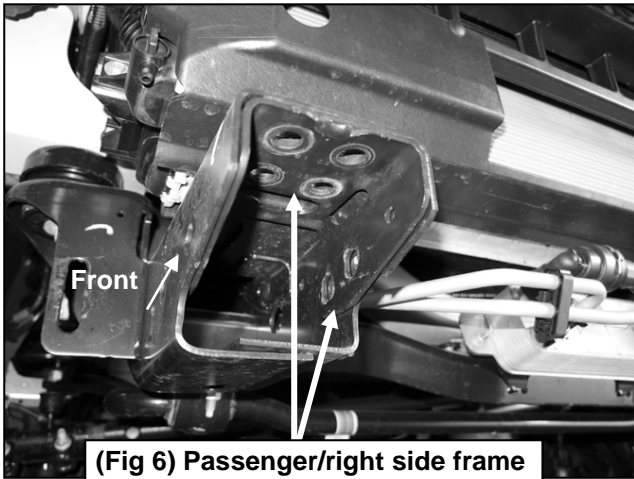

(Fig 6) Passenger/right side frame mounting location

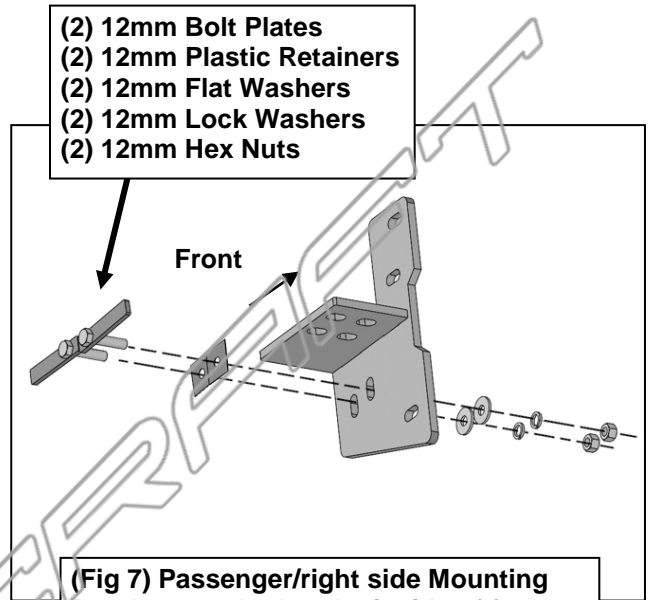

- (2) 12mm Bolt Plates
- (2) 12mm Plastic Retainers
- (2) 12mm Flat Washers
- (2) 12mm Lock Washers
- (2) 12mm Hex Nuts

(Fig 7) Passenger/right side Mounting Bracket attached to the inside of frame

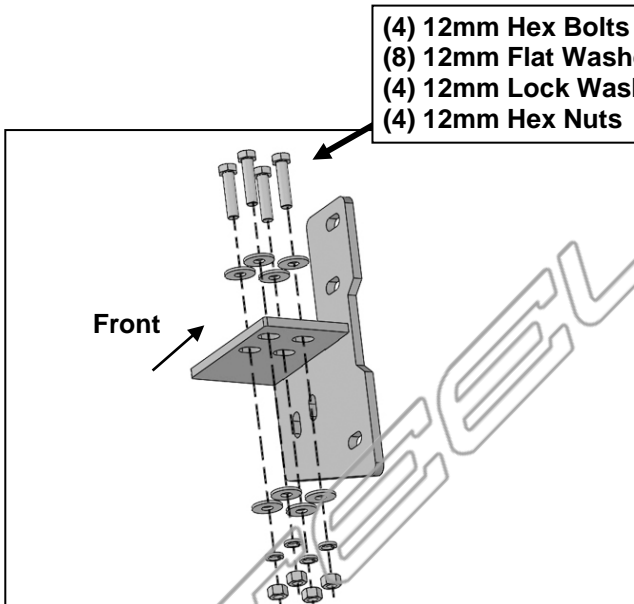

- (4) 12mm Hex Bolts
- (8) 12mm Flat Washers
- (4) 12mm Lock Washers
- (4) 12mm Hex Nuts

(Fig 8) Passenger/right side Mounting Bracket attached to top of frame

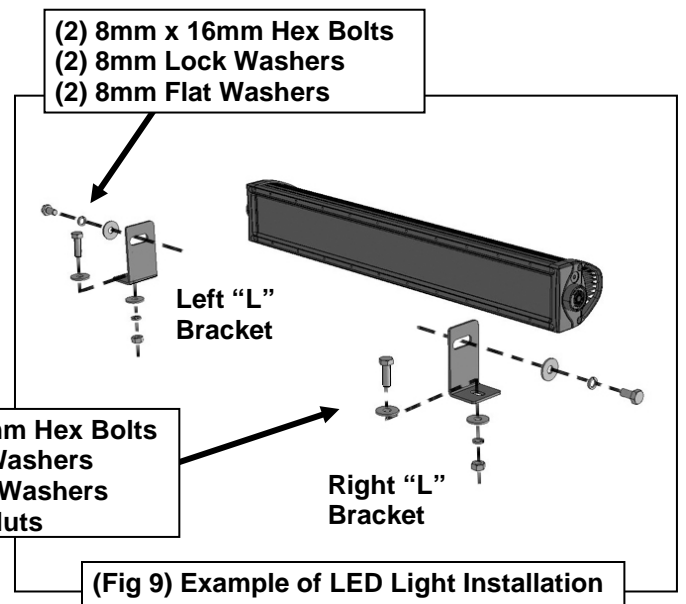

- (2) 8mm x 16mm Hex Bolts
- (2) 8mm Lock Washers
- (2) 8mm Flat Washers

- (2) 8mm x 25mm Hex Bolts
- (4) 8mm Flat Washers
- (2) 8mm Lock Washers
- (2) 8mm Hex Nuts

(Fig 9) Example of LED Light Installation

**FORTIS FRONT BUMPER
2017 FORD SUPERDUTY F250-350**

- (3) 6mm Button Head Bolts
- (3) 6mm Flat Washers
- (3) 6mm Lock Washers
- (3) 6mm Hex Nuts

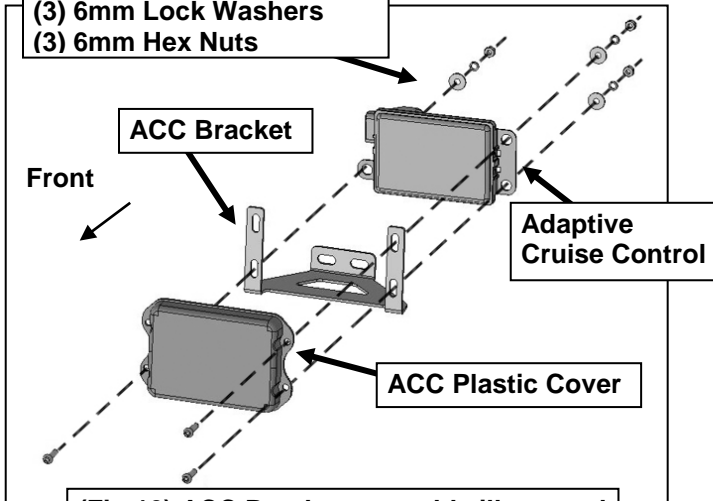

(Fig 10) ACC Bracket assembly illustrated

- (2) 8mm x 25mm Hex Bolts
- (4) 8mm Flat Washers
- (2) 8mm Lock Washers
- (2) 8mm Hex Nuts

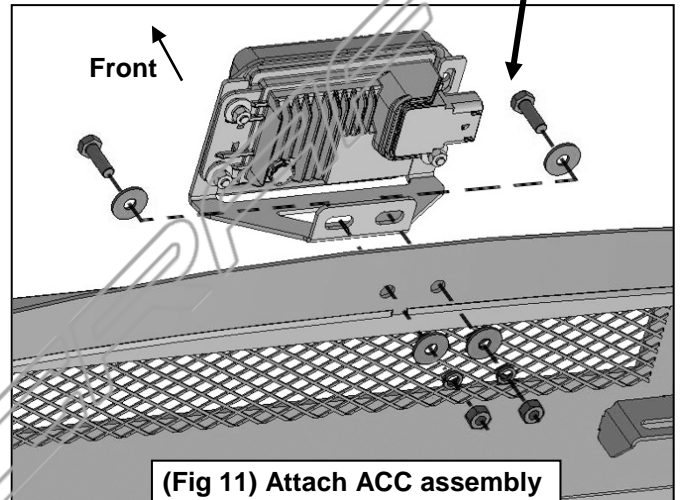

(Fig 11) Attach ACC assembly to front of Bumper

- (3) 12mm Hex Bolts
- (6) 12mm Flat Washers
- (3) 12mm Lock Washers
- (3) 12mm Hex Nuts

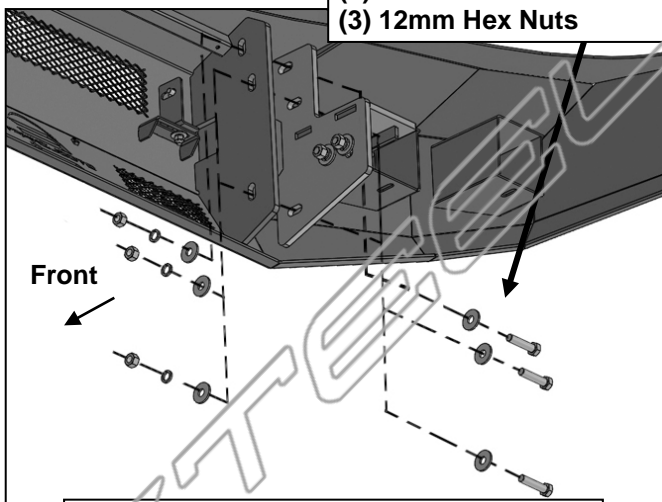

(Fig 12) Passenger/right side Mounting Bracket attached to Bumper

WARNING! Do not crawl under bumper unless the bumper is properly supported on blocks or stands or the bumper may fall.

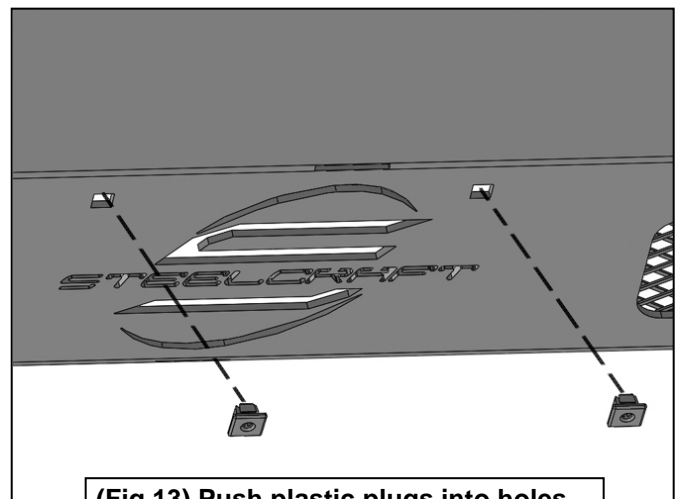

(Fig 13) Push plastic plugs into holes in Bumper for license plate if required